

## LPM/LMM616 AC-DC Modular Power Supply

5V, 10V, 12V, 20V, 24V, 36V & 48V  
Single-Output Modules;  
10V, 20V Dual-Output Modules



### Key Features & Benefits

- **Wide input voltage range from DC to 440 Hz AC**
- **Standard output voltages of 1.5 to 54 VDC**
- Efficiencies up to 86% typical
- Extra-Low 1U profile: 1.6 inch
- High power density design of 18 Watts/cubic inch
- 1 to 6 isolated output slots, fully user configurable
- Power Factor Correction (PFC) IEC 61000-3-2 compliant
- 1300W @ 115 VAC or 1600W @ 230VAC of total output power
- Zero-load operation
- Single-wire current sharing
- Universal input AC range
- Individual control signals on each module
- Auxiliary power 5V (1A)

### Applications

#### LPM616 (Industrial)

- Industrial equipment
- Telecommunications
- Test and measurement
- Automation
- Peripherals
- Audio/broadcast
- Linear and rotary motion

#### LMM616 (Medical)

- Imaging Equipment
- Anesthesiology
- Surgical Devices
- Diagnostic Equipment
- Patient Beds
- Home Healthcare
- Ultrasound

The LPM/LMM616 Series is a modular 1600 Watt AC-DC power supply that provides a market-leading power density of 18 watts per cubic inch and has an extra low 1U profile. The LMM is the medically approved version. From here on only the LPM version will be discussed, differences for the LMM version will be noted. The LPM616 offers the flexibility of a modular architecture and the combination of high efficiency and high power density.

Designed for use where a unique set of voltage and current requirements is needed, the supply's six slots can be configured with PCB-based output modules to deliver up to twelve outputs. The LPM output modules operate in any chassis position and can provide up to 1600 watts total power from a 150 VAC input and 1300 watts from a 100 VAC input. Forced-air cooling with airflow direction from input to output is provided by internal fans.

For LPM616 supplies using less than the six-slot capability, blanking plates are installed for safety purposes and to optimize airflow within the chassis. The supplies are pre-set with default output module settings or with the customer's desired output settings prior to delivery.

The LPM616 chassis can be populated with the output modules listed in Module Selection table. Conformal coating is available on request, please consult with the factory.

# LPM/LMM616

北京泰达华芯科技发展有限公司 代理 电话：010-57425478 邮箱：sales001@power-teda.com

## 1. Module Selection

MODULE	P/N <sup>3</sup>	NO. OF SLOTS REQUIRED	FACTORY-SET SINGLE-OUTPUT (VDC)	MODULE ADJUSTABLE RANGE (VDC)	MAX. OUTPUT CURRENT (AMPS)	MAX. OUTPUT POWER <sup>2</sup> (WATTS)
E	LPM126-OUTA1-05	1	5	2.0 to 5.3	53	265
F	LPM126-OUTA1-12	1	12	5.2 to 15	22	265
G	LPM126-OUTA1-24	1	24	14 to 30	11	265
H	LPM126-OUTA1-36	1	36	29 to 44	7.4	265
J	LPM126-OUTA1-48	1	48	43 to 54	5.5	265
K	LPM109-OUTA1-10	1	15	1.5 to 15	6	90
L	LPM109-OUTA1-20	1	30	3 to 32	3	90
M	LPM118-OUTA2-10	1	15	2x 1.5 to 15	2x 6	2x 90
N	LPM118-OUTA2-20	1	30	2x 3 to 32	2x 3	2x 90
0	LPM100-BLAN	1	Blank Panel (Slot Cover)			

<sup>1</sup> To determine your desired power supply's part number, please refer to *Figure 2* for a detailed part number description. Use the LPM Configurator located in the Modular Section on our website, or use our contacts page to locate a distributor for further assistance.

<sup>2</sup> For the power derating specification please see section 1.4 below.

<sup>3</sup> Add -C for Conformal coating option.

### 1.1. Output Voltage Adjustment

Each LPM616 module's output voltage is adjustable by means of a trimmer located on the module. For the modules E->J the trimmer is accessible through the adjustment hole located on the bottom of the power supply (*Figure 10*). For the modules K->N the trimmer is accessible from rear side of the power supply (*Figure 5*).

### 1.2. Parallel Connections

Depending on certain situations where current requirements exceed one module's capability, the configurator will process a solution using parallel connections. Paralleling busbars are available to make connections requiring higher current needs. For correct current sharing functionality it is necessary to interconnect Current Share pins of the modules that will operate in parallel using signal wires. Only E-J modules can be connected in parallel. For more details read the section 10.3, see *Figure 15*.

### 1.3. Serial Connections

To increase output voltage it is possible to connect modules in series. Serial busbars are available (see section 10.4) to make connections requiring higher voltage needs. The output of LPM616 is rated as SELV circuit, so the output voltages are guaranteed to be less than 60V. The series combination of modules can exceed this SELV voltage, so in this case the users must take adequate precautions to prevent direct contact with conductive parts. The maximal total voltage **must not exceed 200 V**. It is recommended to only connect the same modules with same output current rating. The voltage sense pins VS+, VS- available on modules LPM126 must be connected according to *Figure 17*.

### 1.4. Power Derating

When specifying an LPM616 power supply in an application it is necessary to ensure that LPM616-CHAS and modules (LPM126, LPM118 and LPM109) are operating within their power output capabilities, taking into account the temperature derating and input voltage derating. The maximum permissible output power that may be drawn from LPM616-CHAS and modules is given in the *Figure 1*.

北京泰达华芯科技发展有限公司 代理 电话：010-57425478 邮箱：sales001@power-teda.com

# LPM/LMM616

北京泰达华芯科技发展有限公司 代理 电话：010-57425478 邮箱：sales001@power-teda.com

Figure 1 - Power Derating Curves

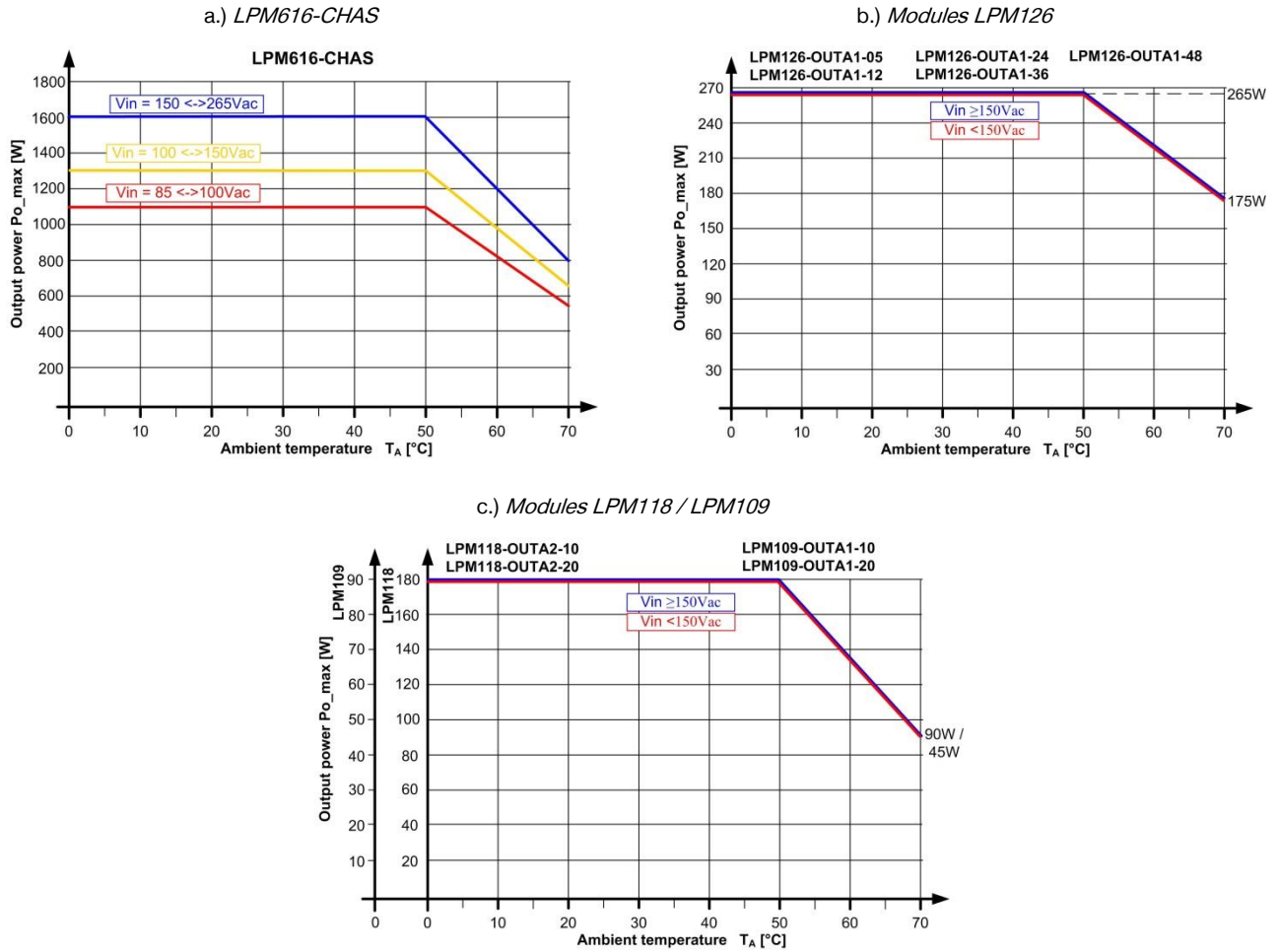

## 2. Part Numbering and Ordering Information

### 2.1. Chassis Identification Numbering

First left-to-right sequence of the part number (4 characters):

- LPM616 Low Profile Modular 6-slot, 1600 W, with single-phase AC input. (Figure 2)

**NOTE:** Chassis and modules are RoHS-6 compliant.

Figure 2 - LPM 6-Slot Model Part Number Description

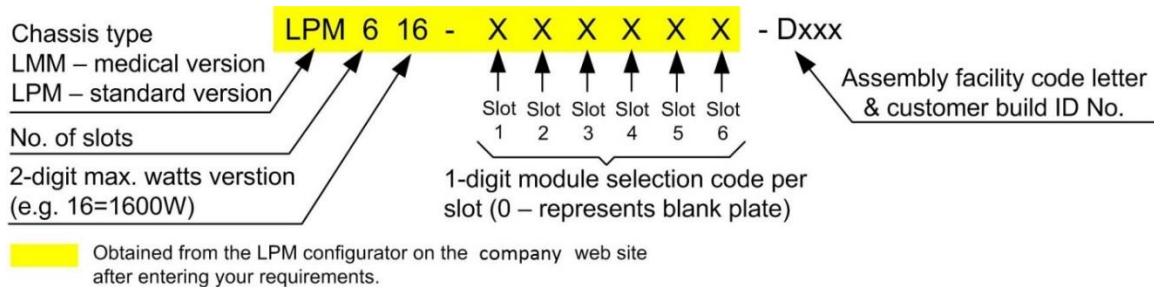

# LPM/LMM616

北京泰达华芯科技发展有限公司 代理 电话：010-57425478 邮箱：sales001@power-teda.com

**Example:** After entering your requirements, the web Configurator optimized part number recommended could be: LPM616-000HEG-DXXX which represents: Low Profile Modular Series with single-phase AC input, 6-slot, 1600 W chassis with modules of: 3x blank panel “0” in slots 1 to 3, modules H, E, G in slots 4 to 6, respectively. Besides the blank panels in slots 1-3, the example's modules in this case would represent desired DC output voltages as follows: Slot 4 = H for 36V, Slot 5 = E for 3.3V and Slot 6 = G for 24V.

Assembly facility code and customer build ID No. are established during actual power supply assembly.

The slots numbering when viewing the unit from the rear, or output side is 1 - 6 from left to right.

## 3. Safety Specifications

### 3.1. Safety Approvals

#### LPM616 (Industrial)

- UL/CSA 60950-1 2nd
- IEC 60950-1 2nd
- EN 60950-1 2nd
- CE Mark for LVD

#### LMM616 (Medical)

- UL/CSA 60601-1, 3rd
- IEC 60601-1, 3rd
- EN 60601-1, 3rd



**NOTE:** Agency approvals are limited to 50-60 Hz. If PSU is used on 400 Hz, then unit must be permanently connected to Protective Earth before connecting the supply due to high leakage current.

### 3.2. Insulation Safety Ratings

TEST POINTS	MINIMUM TEST VOLTAGE	INSULATION SAFETY RATING
Input-to-Chassis	2120 Vdc / min. 1s	Basic Insulation
Input-to-Output	4240 Vdc / min. 1s	Reinforced Insulation
Outputs-to-Chassis	200 Vdc / min. 1s	Functional Insulation
Output-to-Output	200 Vdc / min. 1s	Functional Insulation

## 4. Environmental and Reliability Specifications

### 4.1. Environmental Specification

PARAMETER	CONDITIONS / DESCRIPTION	MIN	NOM	MAX	UNITS
Cooling	Internal DC fan, air intake is from the AC connector side exiting at the DC module side				
Audible Noise	Single unit, 6 modules assembled and full loaded, on a table at 1m distance		56	70	dBA
Operating Temperature	Full power; derated linearly from 100% load @ 50°C to 50% load @ 70°C (for detail see section 1.4)	-20	25	50	°C
Storage Temperature		-40		75	°C
Humidity	95% relative humidity @ 25 °C, non-condensing				
Vibration	Operating: Swept 5-500-5Hz profile, 3 axis, 5 sweep cycles per axis			1	Gpk
	Non-operating: Swept 5-500-5Hz profile, 3 axis, 5 sweep cycles per axis			4	Gpk
Shock	Operating: 11ms, half sine, 10 shocks per face			20	Gpk
	Non-operating: 11ms, half sine, 3 shocks per face			40	Gpk

### 4.2. Reliability

PARAMETER	CONDITIONS / DESCRIPTION	MIN	NOM	MAX	UNITS
Calculated MTBF	According to MIL-HDBK217, Ground benign 30°C, <b>NOTE:</b> Calculation was done for LPM616-EFGHJJ	250,000			hours
Demonstrated MTBF	Tamb = 25°C	250,000			hours

# LPM/LMM616

北京泰达华芯科技发展有限公司 代理 电话：010-57425478 邮箱：sales001@power-teda.com

## 5. Fault Protection

PARAMETER	CONDITIONS / DESCRIPTION	MIN	NOM	MAX	UNITS
Input Fuse	One fuse, non-user serviceable, located on line leg of AC input, Fast Acting type		16		A
Inrush Current Limitation	Provided by NTC	See <i>Input Specification</i> section			
Short Circuit Protection	Provided by Current Limit circuit	105 <sup>1</sup>		125 <sup>1</sup>	% Io_nom
Output Overvoltage Protection	Latching (unit needs to be turned-off and on)	10		25	% Vo_nom
Over Temperature	OT with auto restart			70	°C amb

<sup>1</sup> 100-150% for K, M modules  
100-200% for L, N modules

## 6. EMC Specifications

### 6.1. EMC Immunity

PARAMETER	CONDITIONS / DESCRIPTION	CRITERION
Electrostatic Discharge (ESD)	IEC/EN61000-4-2; GR-1089 R2-1, R2-2, R2-3 Level 4: contact: ±8 kV, air: ± 15kV	Perform, criterion B
RF Susceptibility	IEC/EN 61000-4-3; Level 3: 10 V/m; 80 MHz to 1000 MHz; AM 80%, 1 kHz radiated; RF electromagnetic field	Perform, criterion A
Fast transient / burst	IEC/EN 61000-4-4; Level 3; ±2 kV, 5kHz electrical fast transient / burst immunity test	Perform, criterion B
Surge	IEC61000-4-5, level 3; line to earth: ± 2kV, line to line: ± 1kV surge immunity test	Perform, criterion B
RF conducted disturbance	IEC/EN 61000-4-6; Level 3; GR-108; 10V, 0.15 to 80MHz, AM 80%, 1kHz	Perform, criterion A
Voltage dips / short interruptions	IEC/EN 61000-4-11; Voltage dips, interruptions and variations. (Interpretation: dip below Vi min with Po nom = hold-up time 10 ms) 1a: Dip 30%, 100ms	Perform, criterion B
	1a: Dip 30%, 200ms	Perform, criterion B
	1a: Dip 60%, 10ms	Perform, criterion A
	1a: Dip 60%, 100ms	Perform, criterion B
	1a: Dip >95%, 10ms (interruption)	Perform, criterion A
	1a: Dip >95%, 100ms (interruption)	Perform, criterion B

### 6.2. EMC Emission

PARAMETER	CONDITIONS / DESCRIPTION	CRITERION
Conducted Emission EN55022, FCC	EN 55022, FCC – EN 55022, and CISPR 22 Class B, FCC 47CFR15 unintentional radiators; standalone at all nominal input voltages and measured in Po1: 0, 50%, 100%; signal connections open	Class B; min. 3dB/μV margin
Radiated Emission EN55022, FCC	EN 55022, FCC – EN 55022, and CISPR 22 Class B, FCC 47CFR15 unintentional radiators; standalone at all nominal input voltages and measured in Po1: 0, 50%, 100%; signal connections open	Radiated Class B QSP / AVG min. 3 dB margin
Input Current Harmonics	EN 61000-3-2, sine wave input, Class D; measured standalone at all Vin nominal at power levels between 0 and rated	Pass



# LPM/LMM616

北京泰达华芯科技发展有限公司 代理 电话：010-57425478 邮箱：sales001@power-teda.com

## 7. Electrical Specifications

### 7.1. Input Specification

PARAMETER	CONDITIONS / DESCRIPTION	MIN	NOM	MAX	UNITS
Input AC Voltage Range	Continuous Voltage Range Po=1100W from 85-100 VAC Po=1300W from 100-150 VAC Po=1600W from 150-264 VAC	85	115/230	264	VAC
Input DC Voltage Range	Po=1100W from 120-140 VDC Po=1300W from 140-210 VDC Po=1600W from 210-380 VDC	120		380 <sup>3</sup>	VDC
Input Overvoltage Range	At max. power, no input OVP shutdown			300	VAC
Ground continuity				0.1 <sup>1</sup>	Ohm
Leakage Current	@ 264 VAC, 60Hz, Commercial LPM / Medical LMM			1.5 / 0.5	mA
Frequency	AC line	47	50/60/400	440	Hz
Power Factor	Active PFC meets requirements of EN 61000-3-2 at full load, 120/230 VAC input	0.98			
Input Current	Steady state, 85 VAC at 1100W			16	A rms
Inrush Current	180 VAC, Max Power, 25°C, acc. prETS300-132-1 230 VAC, Max Power, 25°C, acc. prETS300-132-1 (Repeat rate >1min)		60		A pk
Efficiency <sup>2</sup>	Vi = 230 VAC 100% loading	85	86		%
	Vi = 230 VAC 30-80% loading	82	83		%
	Vi = 115 VAC 100% loading	82	83		%
	Vi = 115 VAC 30-80% loading	78	80		%

<sup>1</sup> For any combination of output modules, any valid load and voltage setting

<sup>2</sup> Efficiency typical for standard configuration EFGHJJ and nominal output voltage settings

<sup>3</sup> Vin max=240Vdc for LMM version

### 7.2. Output Specification

PARAMETER	CONDITIONS/DESCRIPTION	MIN	NOM	MAX	UNITS
Output Power	Two fans for internal cooling		1600		W
Output DC Voltages / Modules	All output modules work in any chassis position and are max 1U high PCB-based			-	
Current Share <sup>3</sup>	Active single-wire current share (modules E-J) Maximum difference in currents between two modules – percentage of one module nominal current.			±10	%
Line Regulation	Input from 85 to 264 VAC, 80% load		1.0		% Vo_nom
Load Regulation	From 0-100% load, Input >180VAC, Vo_nom		1.0		% Vo_nom
Thermal Drift	After 15 minute warm-up period		0.02		%/°C
Total Regulation	Variation of line, load and temperature drift		2.0		% Vo_nom
Output Adjust. Range		See <i>Module Selection Table 1</i>			
Dynamic Response	Deviation for 10-90% or 90-10% load changes at a rate of 1A/μs, (constant current mode, Vo reach 1% band around Voset)			4% <sup>1,2</sup> 2000μs	-
	Deviation for 50-100% or 100-50% load steps with 1A/μs rate. (constant current mode, Vo reach 1% band around Voset)			3% <sup>1</sup> 400μs	-
Output Ripple & Noise	BW = 20MHz; Filter 10nF/10uF; over line and load, 25°C			1% of Vo_nom <sup>1</sup>	mVpk-pk
CM Noise	Output to chassis, over line and load (Measured across 50 Ohms, with 10μH / 10nF in parallel)		220	500	mVpp
Overshoot	Output voltage overshoot at turn-on		4		% Vo_nom

## LPM/LMM616

Turn-On Characteristics	Turn ON at minimum and nominal output current	Monotonous characteristic	-	
Turn-Off Characteristics	Turn OFF at minimum and nominal output current	Monotonous characteristic	-	
Turn-On Time	Time required for output within regulation after initial application of AC input		1.5	s
	Time required for output within regulation after removing inhibit		100	ms
Hold-up Time	Vo is required to stay within 95% regulation after AC is removed. Measured from the last AC peak, VAC min and full load.	10		ms
Remote Sense <sup>3</sup>	Total compensation for cable losses	250	500	mV
Over-current Protect.	Automatic recovery / Hiccup by K-N modules		130 - 180	%

<sup>1</sup> the E module dynamic deviation is less than 6%, the E, K, M module ripple is less than 2%

<sup>2</sup> the K and M module dynamic deviation is less than 7% and response time is below 1000us

<sup>3</sup> except K-N modules

### 7.3. Input - Signals, Features and Indicators Description

SIGNAL NAME	PIN	DESCRIPTION
Auxiliary Output - 5V -	1,2 vs 3,4 (RTN_D)	Output is available when the AC input is over 85VAC. The output nominal output voltage is 5.0V at maximum current rating of 1.0A. Over current protection occurs above 1.5A. The output is referenced to logic return, RTN_D.
Input AC Indication - PFAIL -	5	Open Collector output with 20mA pull-down capability referenced to logic return RTN_D. PFAIL open or High state indicates the warning that the input is out of the limit ( the input voltage falls below 85Vac or rises over 264Vac ) 5 ms before the output goes below the lower regulation limit. PFAIL will turn-off the green Input OK LED. PFAIL LOW state indicates that the input voltage is within the operating range.
Fan Fail / OTP Indication - FAN_FAIL -	6	Open Collector output pin with 20mA pull-down capability referenced to logic return RTN_D. FAN_FAIL open or High state indicates the fan fail / over temperature condition min. 100 ms before the unit shuts-down. A fan fail / OTP will turn-off the green FAN OK LED. FAN_FAIL LOW state indicates normal fan operation, no OTP.

### 7.4. Output - Signals, Features and Indicators Description

#### 7.4.1. Modules E, F, G, H, J

SIGNAL NAME	PIN	DESCRIPTION
Positive Sense Wire - VS+ -	1	Output voltage sense wire. Internally connected to Vout+ via 51 Ω. It is recommended to connect sense wire at positive load point.
Negative Sense Wire - VS- -	2	Output voltage sense wire. Internally connected to Vout- via 51 Ω. It is recommended to connect sense wire at negative load point.
Current Share - CSH -	3	Common wire for parallel connected modules to achieve proper current sharing between the modules. Referenced to the Common pin. Interconnect CS pin on all parallel working modules. Active current share pin enables control of output voltage. Pulling-up this pin to 5V is possible to increase the output voltage. Pull-down of this pin has no effect. Voltage on this pin is 3.5V at nominal module current.
Common	4	Reference pin to CSH
N/C	5	
N/C	6	
Output Good Indication - PG_HI -	7	Open collector output with 20mA pull-down capability, max. 15V (recommended Rpull-up=1k, Vcc=5V). Referenced to PG_LO. PG_HI open or High state indicates that the module output voltage is below lower regulation limit. A PG_HI fail state turns the GREEN DC OK LED to RED. PG_HI LOW state indicates the module output voltage is within normal operation limits.
- PG_LO -	8	Reference pin to PG_HI
Output Inhibit Function - INH_HI -	9	An opto-isolated input with 2-10mA current capability. Apply +(3-15)V on INH_HI and RTN on INH_LO (e.g. from the Auxiliary Output 5V) to activate the inhibit function. INH_HI OPEN OR LOW state ENABLES the module output. INH_HI HIGH state INHIBITES the module output.
- INH_LO -	10	Reference pin to INH_HI

### 7.4.2. Modules K, L, M, N

SIGNAL NAME	PIN	DESCRIPTION
- INH_LO_B -	1	Reference pin to INH_HI_B
Output Inhibit Function - INH_HI_B -	2	An opto-isolated input with 2-10mA current capability. Apply +(3-15)V on INH_HI_B and RTN on INH_LO_B (e.g. from the Auxiliary Output 5V) to activate the inhibit function. INH_HI OPEN OR LOW state ENABLES the module output. INH_HI HIGH state INHIBIT the module output.
- PG_LO_B -	3	Reference pin to PG_HI_B
Output Good Indication - PG_HI_B -	4	Open collector output with 20mA pull-down capability, max. 15V (recommended Rpull-up=1k, Vcc=5V). Referenced to PG_LO_B. PG_HI open or High state indicates that the module output voltage is below lower regulation limit. A PG_HI fail state turns the GREEN DC OK LED to RED. PG_HI LOW state indicates that the module output voltage is within normal operation limits.
N/C	5	
N/C	6	
- INH_LO_A -	7	Reference pin to INH_HI_A
Output Inhibit Function - INH_HI_A -	8	An opto-isolated input with 2-10mA current capability. Apply +(3-15)V on INH_HI_A and RTN on INH_LO_A (e.g. from the Auxiliary Output 5V) to activate the inhibit function. INH_HI OPEN OR LOW state ENABLES the module output. INH_HI HIGH state INHIBIT the module output.
- PG_LO_A -	9	Reference pin to PG_HI_A
Output Good Indication - PG_HI_A -	10	Open collector output with 20mA pull-down capability, max. 15V (recommended Rpull-up=1k, Vcc=5V). Referenced to PG_LO_A. PG_HI open or High state indicates that the module output voltage is below lower regulation limit. A PG_HI fail state turns the GREEN DC OK LED to RED. PG_HI LOW state indicates that the module output voltage is within normal operation limits.

### 7.5. Visual Alarms Description

ALARM NAME	LED POSITION	DESCRIPTION
Input AC Good	Front panel – LED2 (see Fig.6)	ON state LED indicates operation within specified input voltage range. GREEN LED indicator goes to an OFF condition on PFAIL signal failure state.
Fan Good	Front panel – LED1 (see Fig.6)	ON state LED indicates normal fan operation and no OTP status. GREEN LED indicator goes to an OFF condition on FAN_FAIL / OTP signal failure state.
Output Good	Module connector / rear side (see Fig.7.1)	GREEN LED indicates that module output voltage is within normal operation limits. GREEN LED indicator goes to RED on PG_HI signal failure state.

## 8. Connector Details

### 8.1. Input Connector Information

LPM616 front panel connector pinout refers to *Figure 3* and chapter 8.2 and 8.3. The input signal connector is Cvilux part number: CI3306P1H10, the mating part is Cvilux CI3306S0010, Molex 50-57-9406 or Taiwan King Pin P553L-06(LF).

**NOTE:** See chapter 10.1 Mating Connections and cables for Input cable information.

*Figure 3 - LPM616 Front Panel Connectors Pinout View*





# LPM/LMM616

## 8.2. Input Power Connector - Pinout

SIGNAL NAME	PIN #	TYPE	RECOMMENDED WIRES	V MAX I MAX
Earth		Earth / Chassis	Min. 1,5 mm <sup>2</sup> e.g. Interpower 86230120 Max. torque on screws (M4x6): 1,5 Nm	264 Vrms 16 Arms
AC Neutral	N	Input Power AC		
AC Line	L	Input Power AC Fused		

**CAUTION:**

During the operation must be the input power connector protected by the plastic cover!  
The cover may be removed (by the help of a screwdriver) only when the input cable is disconnected from the mains.

## 8.3. Input Signal Connector – Pinout

(Mating connector: Molex 50-57-9406, Pins: Molex 16-02-0082)

SIGNAL NAME	PIN #	WIRE COLOR	TYPE	SIGNAL REFERENCE	LOW LEVEL HIGH LEVEL	V MAX I MAX
+5V	1	Red	Aux Output	RTN_D	-	5.0Vdc
+5V	2	Red	Aux Output	RTN_D	-	1.0A dc
RTN_D	3	Black	Logic Reference Potential	-	-	-
RTN_D	4	Black	Logic Reference Potential	-	-	-
PFAIL	5	Yellow	Open Collector Output + ZD 5.6V	RTN_D	<400mV@ 20mA Pull up	- 20mA
FAN_FAIL	6	Green	Open Collector Output + ZD 5.6V	RTN_D	<400mV@ 20mA Pull up	- 20mA

## 8.4. Module Power Outputs Pinout

### 8.4.1. Modules E, F, G, H, J - A, B Bus-Bar

SIGNAL NAME	PIN #	TYPE	SIGNAL REFERENCE	LOW LEVEL HIGH LEVEL	V MAX I MAX
Vout+	Vout+	Output Power DC	Vout-	-	See Module Selection Table 1
Vout-	Vout-	Output Power DC	-	-	See Module Selection Table 1

**Connector type:** Bus-bar see *Figure 4*

**Mating part:** Ring terminal for M4 screw, with appropriate cross section for wire.

### 8.4.2. Modules K, L, M, N

SIGNAL NAME	PIN #	TYPE	SIGNAL REFERENCE	LOW LEVEL HIGH LEVEL	V MAX I MAX
Vout1+	Vout1+	Output 1 Power DC	Vout1-	-	See Module Selection Table 1
Vout1-	Vout1-	Output 1 Power DC	-	-	See Module Selection Table 1
Vout2+ <sup>1</sup>	Vout2+	Output 2 Power DC	Vout2-	-	See Module Selection Table 1
Vout2- <sup>1</sup>	Vout2-	Output 2 Power DC	-	-	See Module Selection Table 1

<sup>1</sup> valid only for two outputs modules M and N.

**Connector type:** Phoenix Contact 1803277

**Mating part:** Phoenix Contact 1850660

# LPM/LMM616

Figure 4 - Modules E,F,G,H,J Power Output Connectors

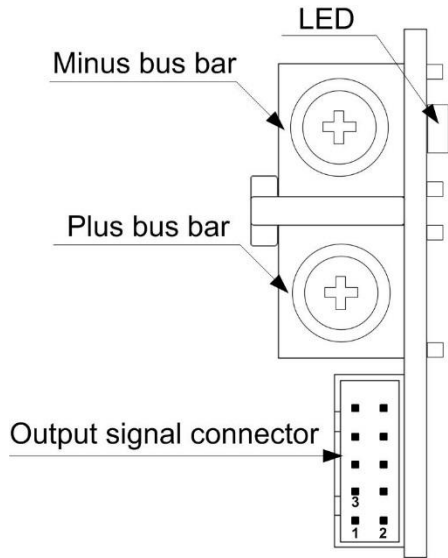

**Note:** Bus bar screw M4x10mm,  
max. torque 1.5Nm

Figure 5 - Modules K,L,M,N Power Output Connectors

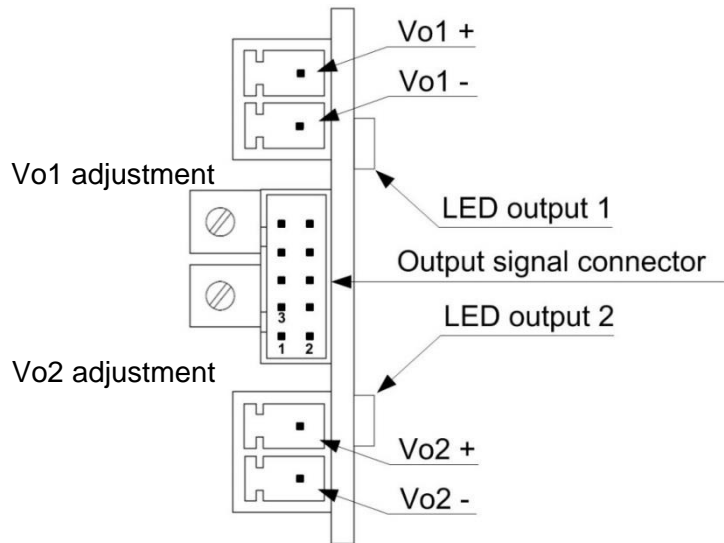

## 8.5. Module Signal Output Connector Pinout

The output signal connector provides signal information across its 10-pin output, for position of the output signal connector please see *Figure 4* and *Figure 5*.

**Connector type:** JST S10B-PHDSS-B

**Mating part:** JST housing PHDR-10VS, Pins SPHD-002T-P0.5 (AWG 28-24) or SPHD-001T-P0.5 (AWG 26-22)

### 8.5.1. Modules E, F, G, H, J

SIGNAL NAME	PIN #	TYPE	SIGNAL REFERENCE	LOW LEVEL HIGH LEVEL	V MAX I MAX
VS+	1	Output voltage sense wire. Internally connected to Vout+ via 51 Ω	Vout+	-	0.5V 10mA
VS-	2	Output voltage sense wire. Internally connected to Vout- via 51 Ω	Vout-	-	0.5V 10mA
CSH	3	Active Current Share pin	Common	-	5V -
Common	4	Reference pin to CSH	-	-	-
N/C	5	-	-	-	-
N/C	6	-	-	-	-
PG_HI	7	Open collector output	PG_LO	<400mV@5mA Pull up	15V 20mA
PG_LO	8	Reference for PG_HI	-	-	- 20mA
INH_HI	9	Input, protected by 18V Zener diode	INH_LO	LED with a serial resistor 2 kOhms	15V 10mA
INH_LO	10	Reference for INH_HI	-	-	- 10mA

### 8.5.2. Modules K, L, M, N

SIGNAL NAME	PIN #	TYPE	SIGNAL REFERENCE	LOW LEVEL HIGH LEVEL	V MAX I MAX
INH_LO_B	1	Reference for INH_HI_B	-	-	- 10mA
INH_HI_B	2	Input, protected by 18V Zener diode	INH_LO_B	LED with a serial resistor 2 kOhms	15V 10mA
PG_LO_B	3	Reference for PG_HI_B	-	-	- 20mA
PG_HI_B	4	Open collector output	PG_LO_B	<400mV@5mA Pull up	15V 20mA
N/C	5	-	-	-	-
N/C	6	-	-	-	-
INH_LO_A	7	Reference for INH_HI_A	-	-	- 10mA
INH_HI_A	8	Input, protected by 18V Zener diode	INH_LO_A	LED with a serial resistor 2 kOhms	15V 10mA
PG_LO_A	9	Reference for PG_HI_A	-	-	- 20mA
PG_HI_A	10	Open collector output	PG_LO_A	<400mV@5mA Pull up	15V 20mA

## 9. Mechanical Drawings

**Overall Dimensions:** 11.9" x 5" x 1.6" (303.7 x 127 x 40.64mm)

**Weight:** 1.94 kg (including 6 modules)

All drawing dimensions are shown in millimeters, unless otherwise noted.

Figure 6 - Front View

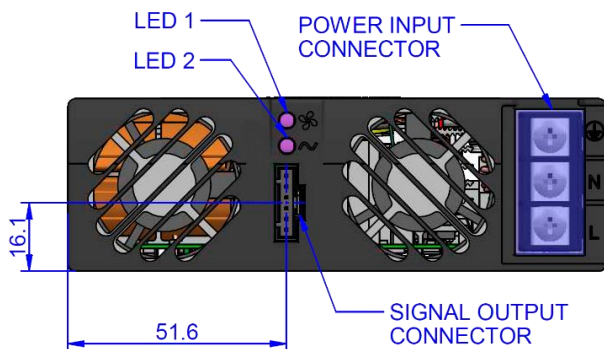

Figure 7 - Rear View

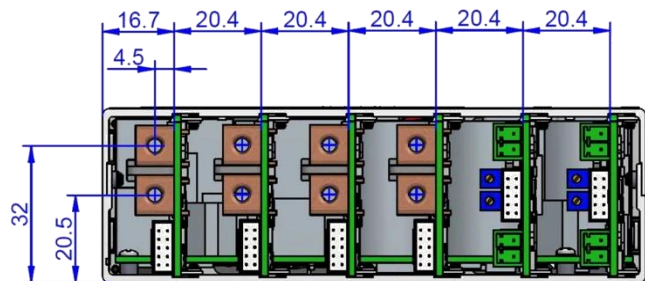

Figure 8 - Side View



Figure 9 - Top View

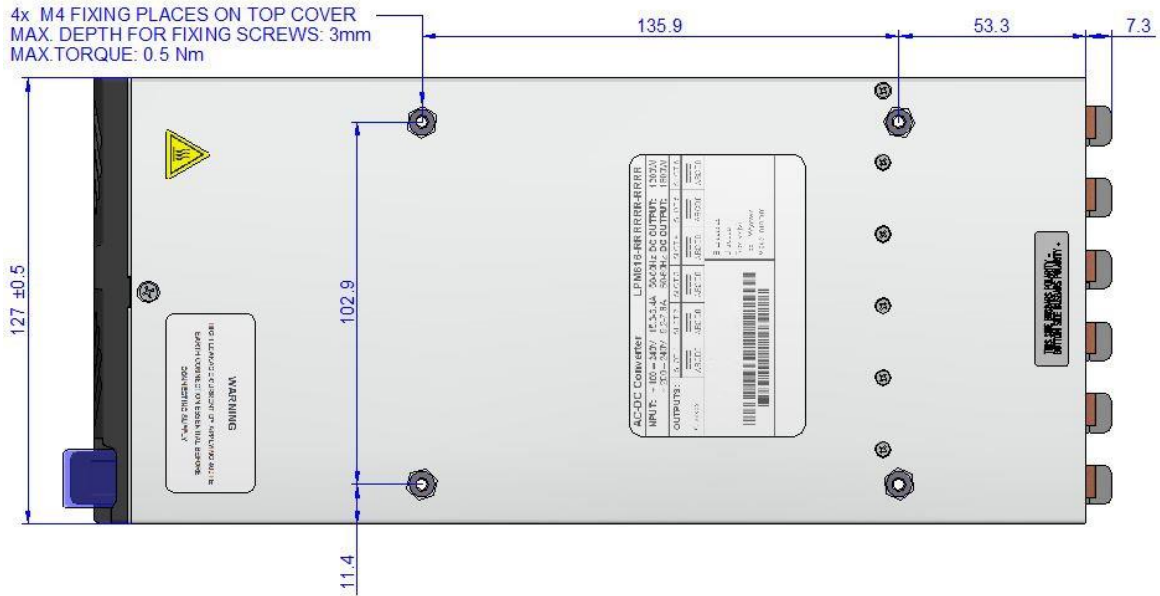
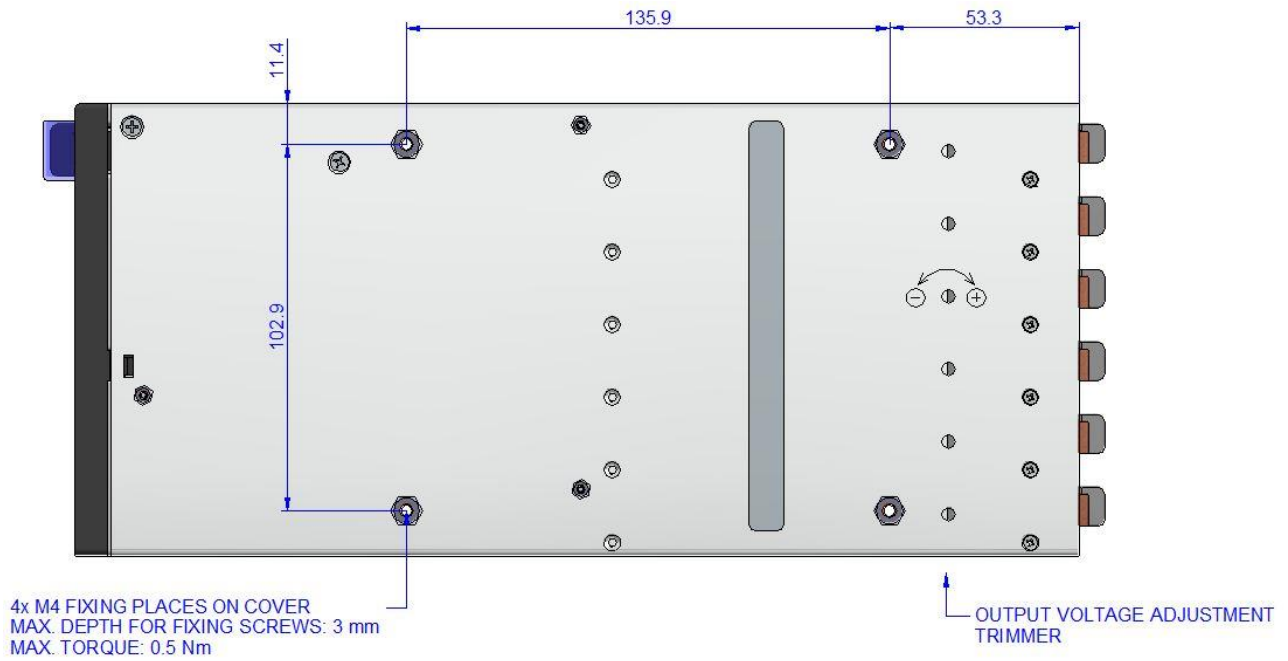

Figure 10 - Bottom View



# LPM/LMM616

## 10. Accessories

### 10.1. Mating Connections and Cables

All the power and signal cables and mating connectors are not included in the LPM616 standard package. These all need to be ordered extra.

Front panel signal cable:	Bel Power Solutions accessory LPM000-LEAD-03	see <i>Figure 11</i>
Output signal cable:	Bel Power Solutions accessory LPM000-LEAD-04	see <i>Figure 12a</i>
Mating connector:	JST, housing PHDR-10VS, pins SPHD-002T-P0.5 (AWG 28-24)	
Output power cable (for LPM126):	14AWG – 10AWG depend on the output current, min. thermal class 105°C, lug terminal 4mm 6mm <sup>2</sup>	
Output power cable (for LPM109/118):	Bel Power Solutions accessory LPM000-LEAD-05,	see <i>Figure 12b</i>



*Figure 11 - LPM000-LEAD-03:  
Front panel signal cable  
(length of the cable 1.8m)*



*Figure 12a - LPM000-LEAD-04:  
Output signal cable  
(length of the cable 0.75m)*



*Figure 12b - LPM000-LEAD-05:  
Output power cable for modules K-N (length  
of the cable 0.75m)*

### 10.2. Signal Output Wire Colors

PIN #	SIGNAL NAME BY MODULES E, F, G, H, J	SIGNAL NAME BY MODULES K, L, M, N	WIRE COLOR
1	VS+	PG_HI_A	Red
2	VS-	PG_LO_A	Blue
3	CSH	INH_HI_A	Yellow
4	Common	INH_LO_A	White
5	N/C	N/C	-
6	N/C	N/C	-
7	PG_HI	PG_HI_B	Violet
8	PG_LO	PG_LO_B	Brown
9	INH_HI	INH_HI_B	Black
10	INH_LO	INH_LO_B	Green



# LPM/LMM616

## 10.3. Paralleling Busbars (only for modules E-J)

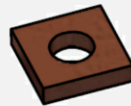
ITEM	DESCRIPTION	MODEL
LPM000-BBAR-07	Busbar for parallel connection of two modules, central screw M5, max. 100A <sup>1</sup> . Two pieces are in one package LPM000-BBAR-07.	
LPM000-BBAR-08	Busbar washer with 1 opening for odd module paralleling. Two pieces are in one package LPM000-BBAR-08.	

**NOTES:**

- <sup>1</sup> For load current over 100A use two or more cables connected to separate busbars.
- <sup>2</sup> By using busbars (paralleling modules) you will need also the signal output leads LPM000-LEAD-04, one for each connected module. The interconnection is shown in *Figure 15* (especially all pins 3 - CSH and all pins 4 - Common must be reconnected).
- <sup>3</sup> Modules K-N cannot be connected in parallel.

The example of LPM616-0000EE-DXXX assembly configuration (two modules in parallel) is shown in *Figure 13*. One set of busbars LPM000-BBAR-07 + 2x LPM-LEAD-04 are necessary for connection.

*Figure 13 - LPM616-0000EE-DXXX Parallel Configuration*

*Figure 14 - LPM616-000EEE-DXXX Parallel Configuration*

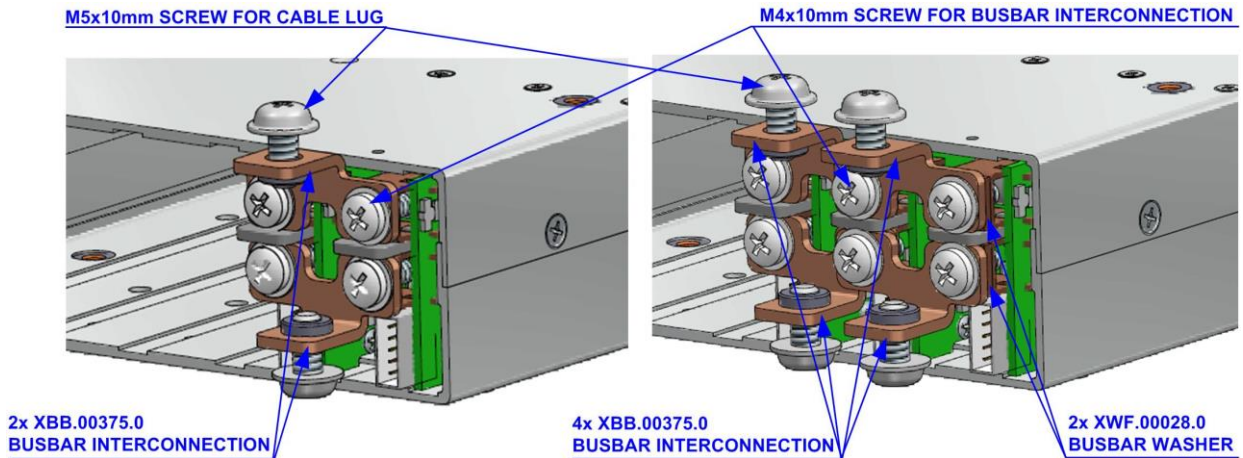

An example of LPM616-000EEE-DXXX assembly configuration (three modules in parallel) is in the *Figure 14*. Two sets of busbars LPM000-BBAR-07 + one set of LPM000-BBAR-08 + 3x LPM-LEAD-04 is necessary for connection.

Note, for odd number of modules in parallel it is necessary to use also one set of busbar washers LPM000-BBAR-08.

To connect the load for higher output currents use more cables for each pole. For example for 300A output current (LPM616-EEEEEE-DXXX) connect minimal three power cables for each pole (3x 42mm<sup>2</sup> for one pole). Use min. 105°C thermal class isolation.



# LPM/LMM616

Figure 15 - LPM616 – Paralleling Connection Diagram for LPM126 Modules

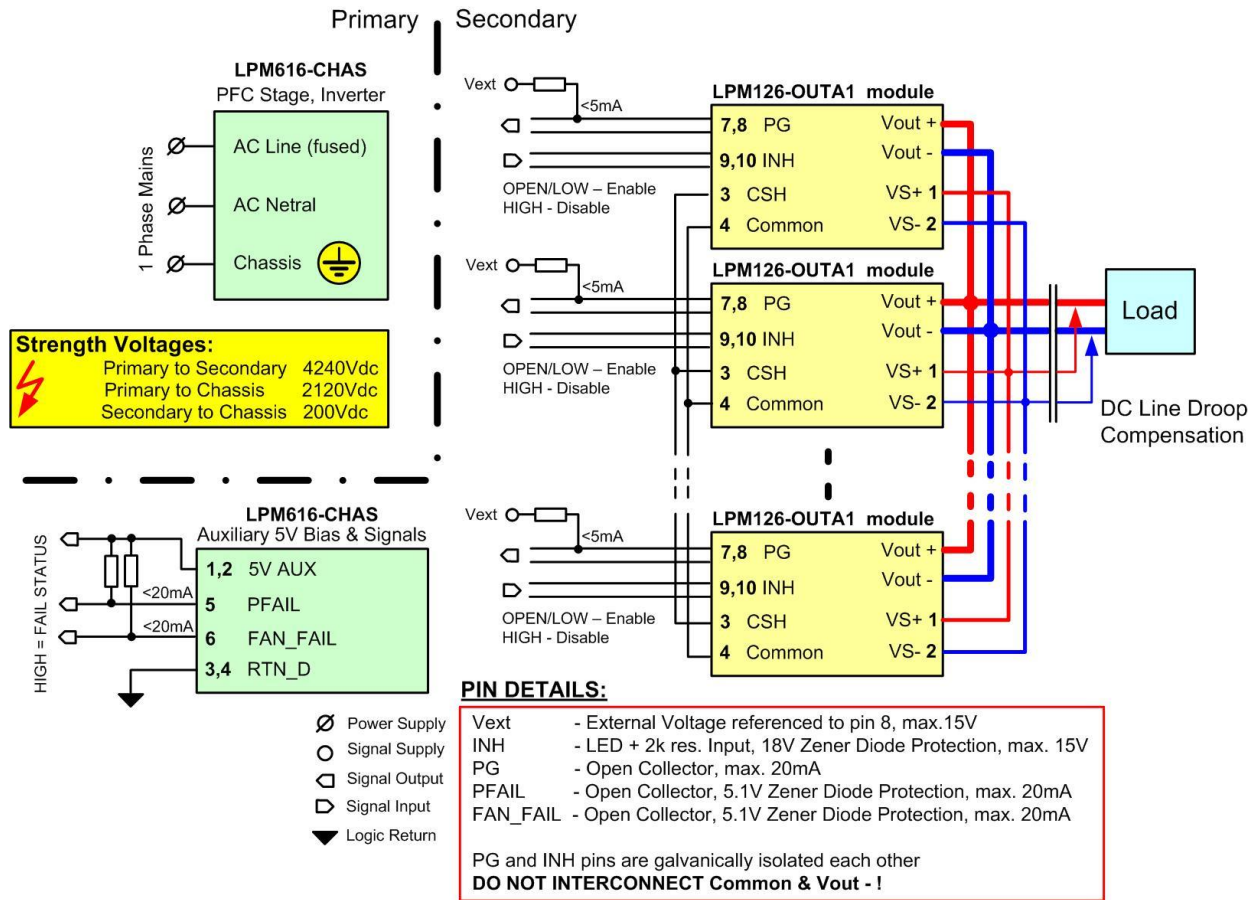

## 10.4. Serial Busbars (only for modules E-J)

ITEM	DESCRIPTION	MODEL
LPM000-BBAR-09	Busbar for serial connection of two modules.	

Figure 16 - LPM616-000EEE-DXXX Serial Configuration



# LPM/LMM616

Figure 17 - LPM616 – Serial Connection Diagram for LPM126 Modules

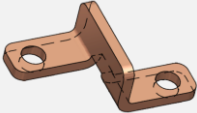
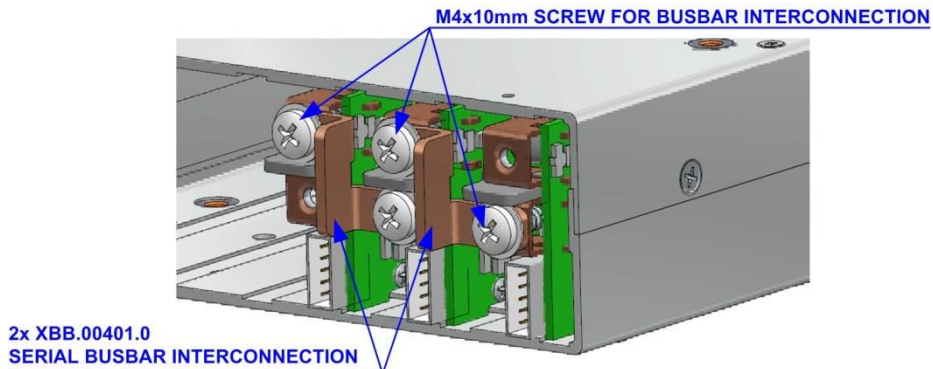
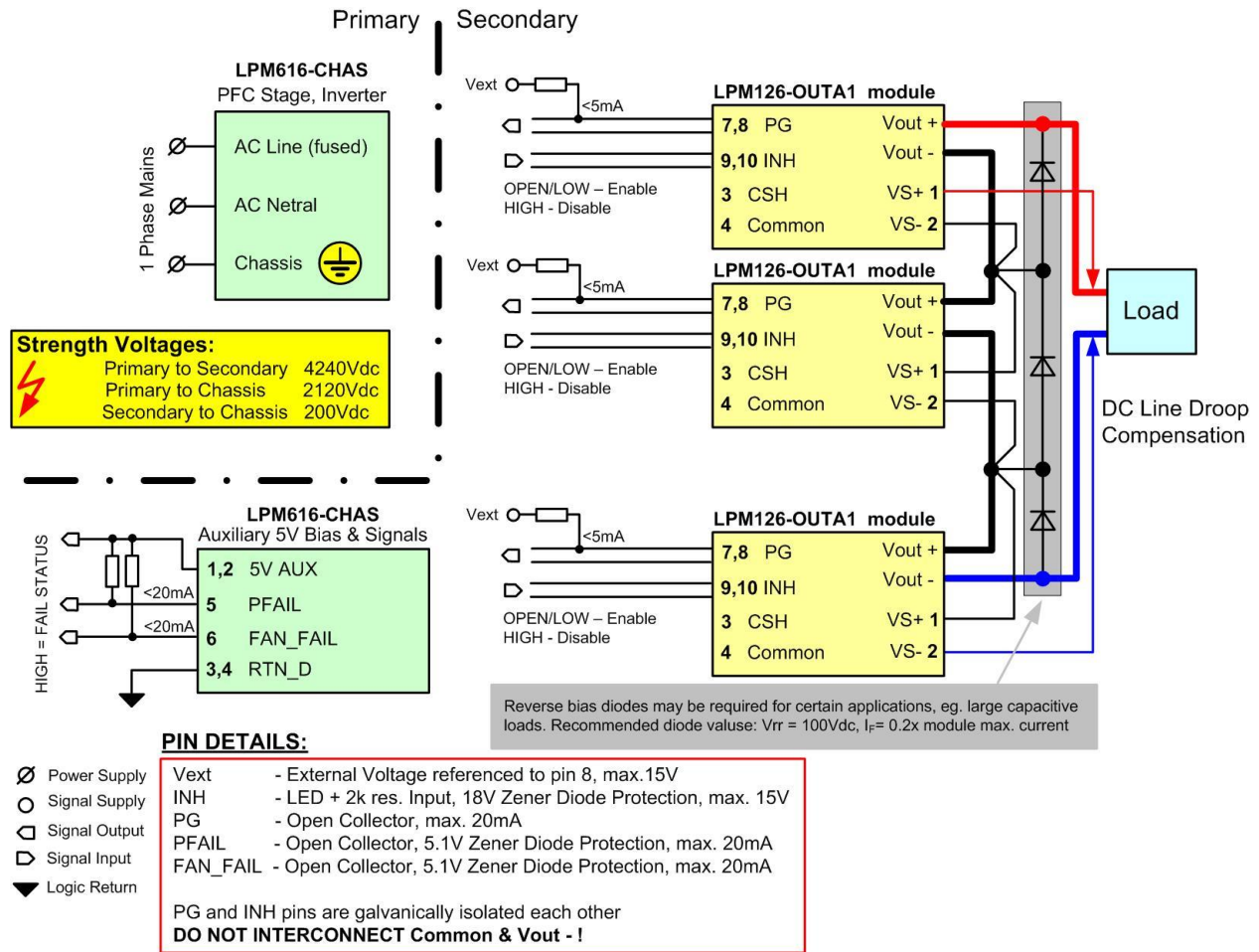

For more information on these products consult: [tech.support@psbel.com](mailto:tech.support@psbel.com)

**NUCLEAR AND MEDICAL APPLICATIONS** - Products are not designed or intended for use as critical components in life support systems, equipment used in hazardous environments, or nuclear control systems.

**TECHNICAL REVISIONS** - The appearance of products, including safety agency certifications pictured on labels, may change depending on the date manufactured. Specifications are subject to change without notice